

mimSAFE

www.mimsafe.se

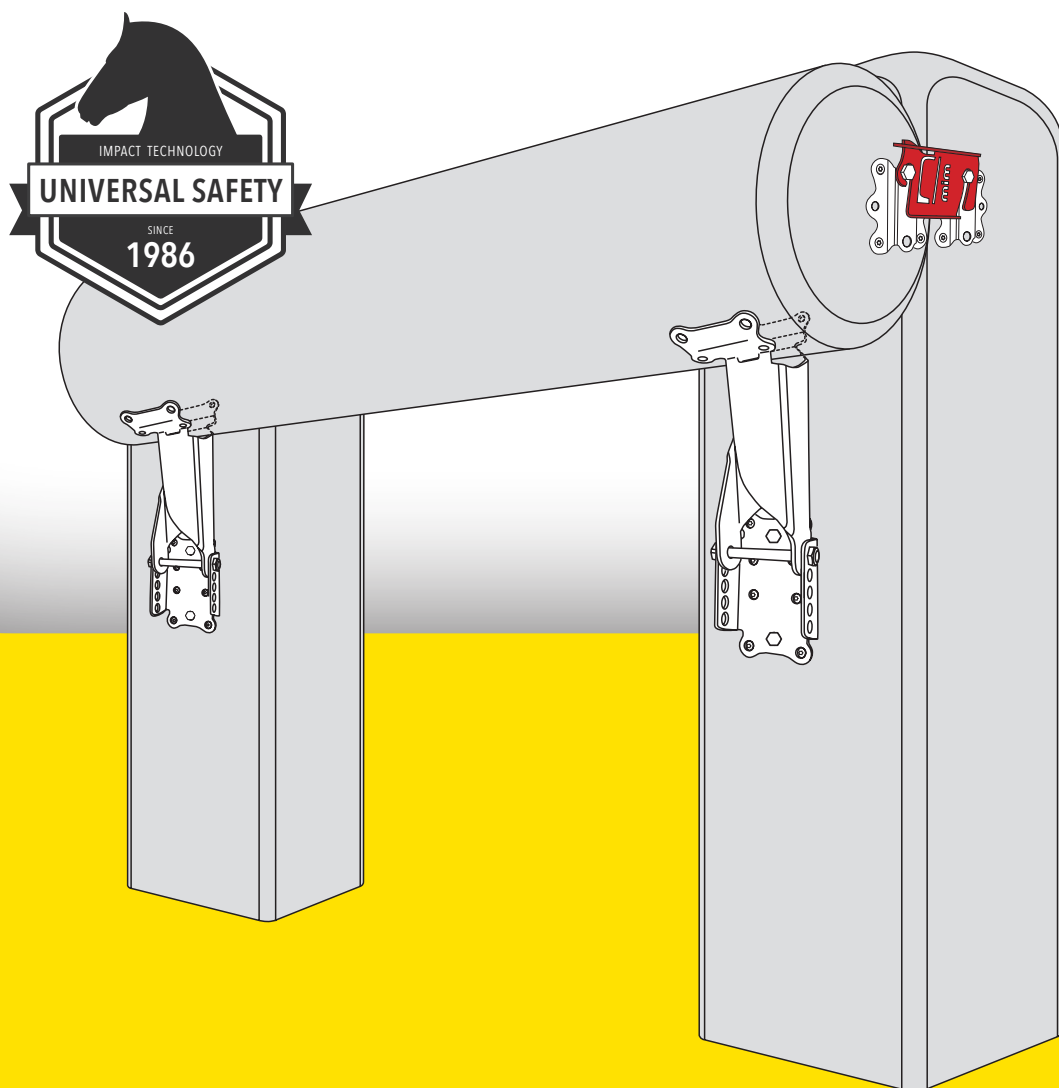

ASSEMBLY INSTRUCTIONS

POST & RAIL KIT

NEWERA USIT SYSTEM





APPROVED

INFORMATION ABOUT THE POST & RAIL KIT

The Post & Rail Kit has been designed and developed specifically to greatly reduce the risk of rotational falls. The most important element of this kit is that it will not break the fence or

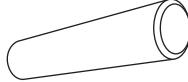
risk injury to the horse if hit vertically. The rail is only released when impacted horizontally by the horse. The risk of a resulting rotational fall is thus reduced.

RECOMMENDED FENCE DIMENSIONS									
<p>POST</p> 	<p>RAIL</p> 								
<p>MIN-MAX SIZE</p> <table border="1"><tr><td>6 - 10</td><td>inch</td></tr><tr><td>150 - 250</td><td>mm</td></tr></table>	6 - 10	inch	150 - 250	mm	<p>MIN-MAX DIAMETER</p> <table border="1"><tr><td>8 - 12</td><td>inch</td></tr><tr><td>200 - 300</td><td>mm</td></tr></table>	8 - 12	inch	200 - 300	mm
6 - 10	inch								
150 - 250	mm								
8 - 12	inch								
200 - 300	mm								
	<p>MAXIMUM LENGTH</p> <table border="1"><tr><td>16.4</td><td>ft</td></tr><tr><td>500</td><td>cm</td></tr></table>	16.4	ft	500	cm				
16.4	ft								
500	cm								
<p>MIN-MAX SIZE</p> <table border="1"><tr><td>6 - 10</td><td>inch</td></tr><tr><td>150 - 250</td><td>mm</td></tr></table>	6 - 10	inch	150 - 250	mm	<p>MAXIMUM WEIGHT</p> <table border="1"><tr><td>440.92</td><td>lb</td></tr><tr><td>200</td><td>kg</td></tr></table>	440.92	lb	200	kg
6 - 10	inch								
150 - 250	mm								
440.92	lb								
200	kg								



It is essential to follow the recommended dimensions on the fence for the correct function. If the recommended procedure is not correctly followed it may cause the failure of the device.

For your own safety and that of others please note the following step by step advice for correct preparation and installation. It is important that you follow your own health and safety requirements when constructing this kit.

Ensure that you have all parts of the Post & Rail Kit.

Be aware of the risk of injury when handling heavy rails, poles and the tools for mounting.

WARNING!

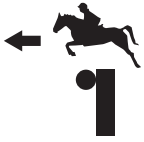

Jumping direction

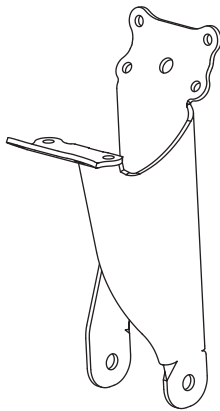
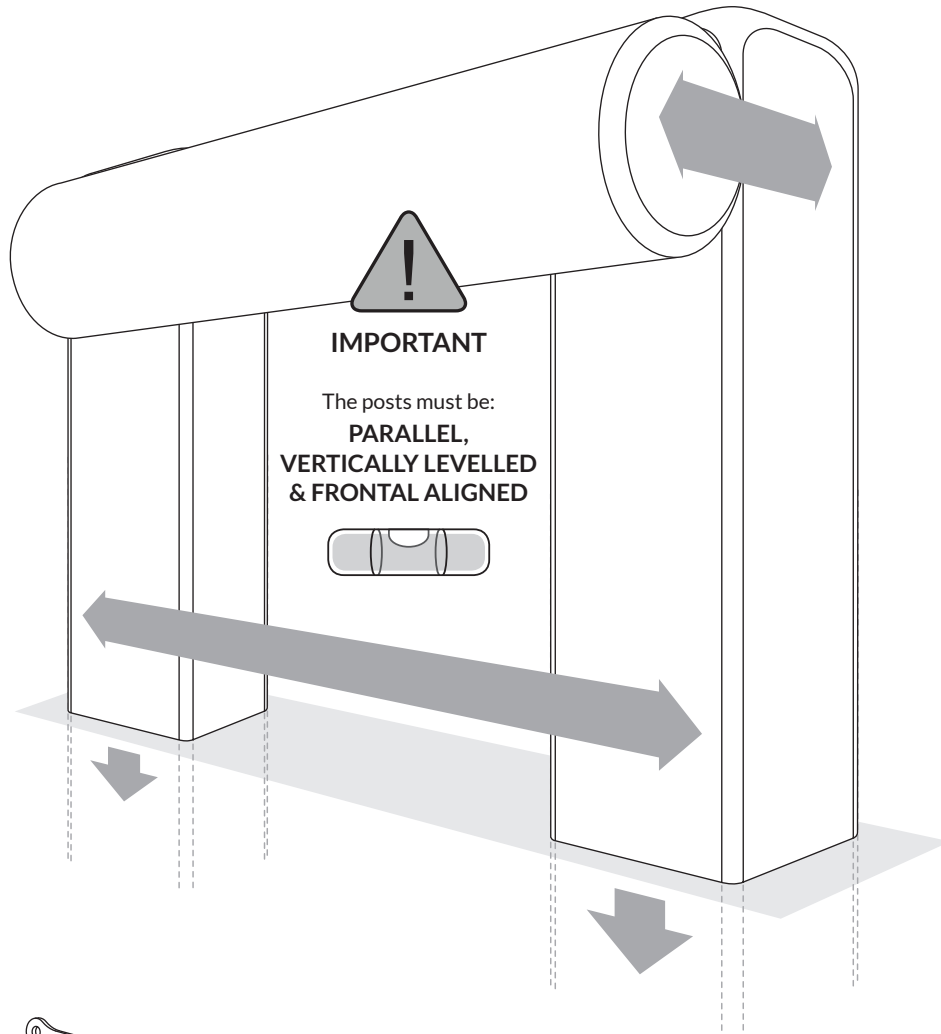

A	F65	2x
	Part no	

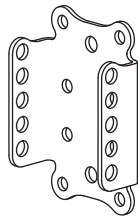

B	F64A5	2x
	Part no	

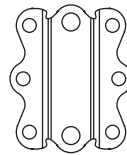

C	F70A	4x
	Part no	





D	F18C	6x
	Part no	

<p>M-SM12x120 2X</p>	<p>M-BR12x22x2s 2X</p>	<p>M-MM12Ny 2X</p>	<p>M-TS10X90 4X</p>	<p>POST 2X</p> <p>not included</p>	<p>RAIL 1X</p> <p>not included</p>
--------------------------	----------------------------	------------------------	-------------------------	--	--

STEP
1

2X

M-SM12x120 2X 	M-BR12x22x2s 2X 	M-MM12Ny 2X 
---	---	---

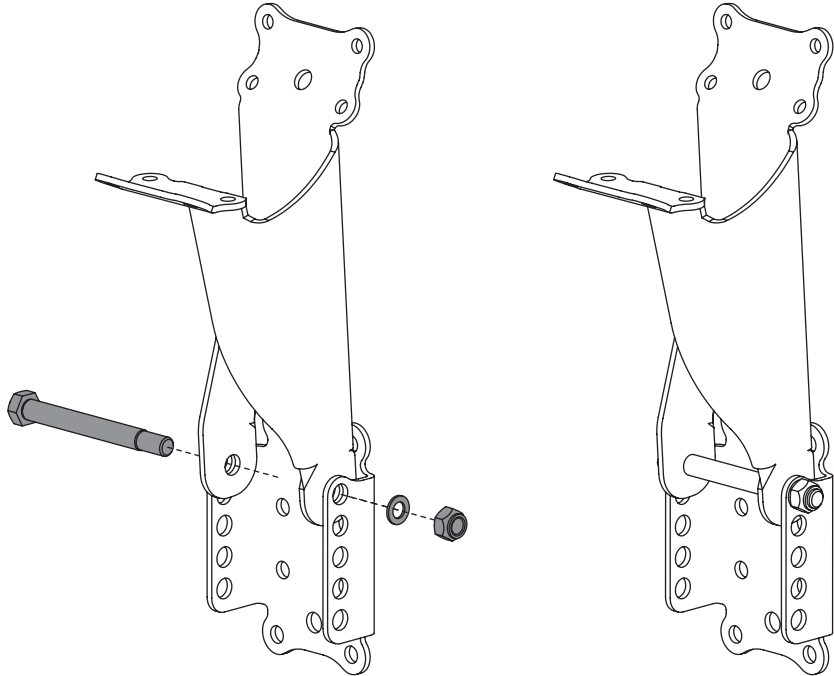
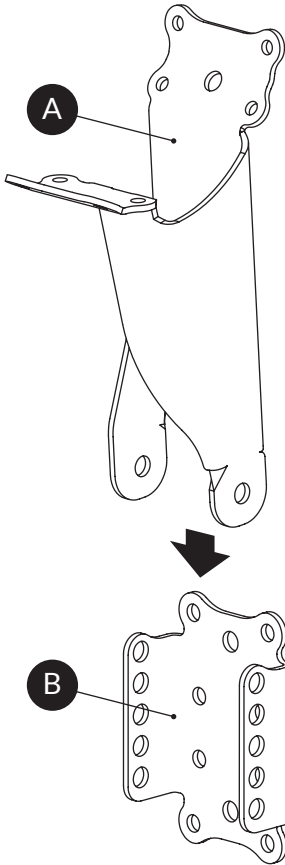

STEP
2

**ADJUST TO
CORRECT POSITION**



IMPORTANT
The **A & B** pieces must be:
PARALLEL



IMPORTANT
The **BOLTS** must be:
ALIGNED

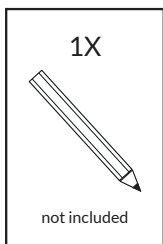
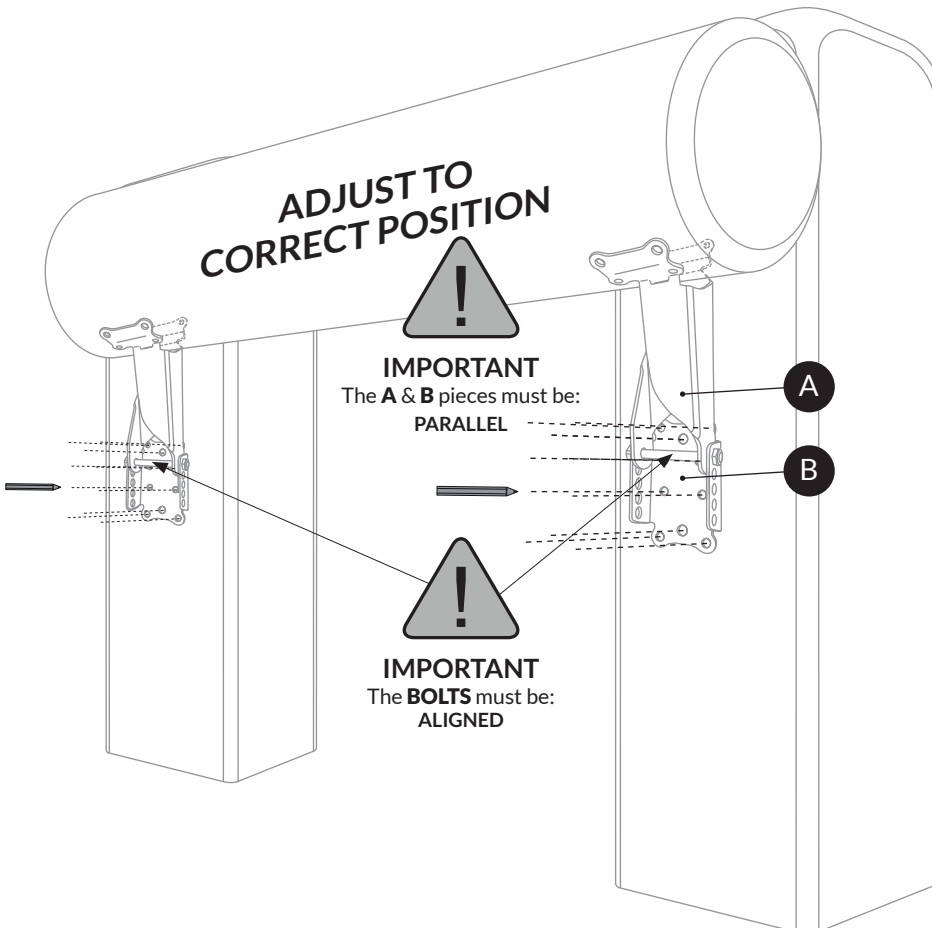

STEP
3

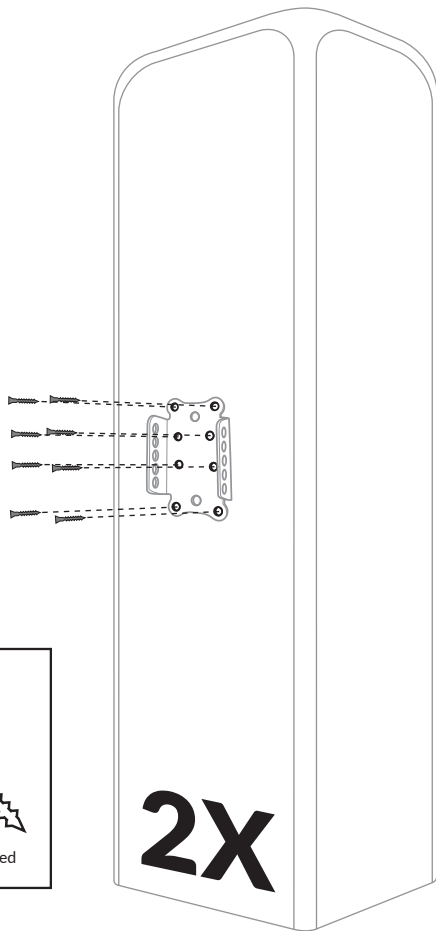

STEP
3*

*alternative

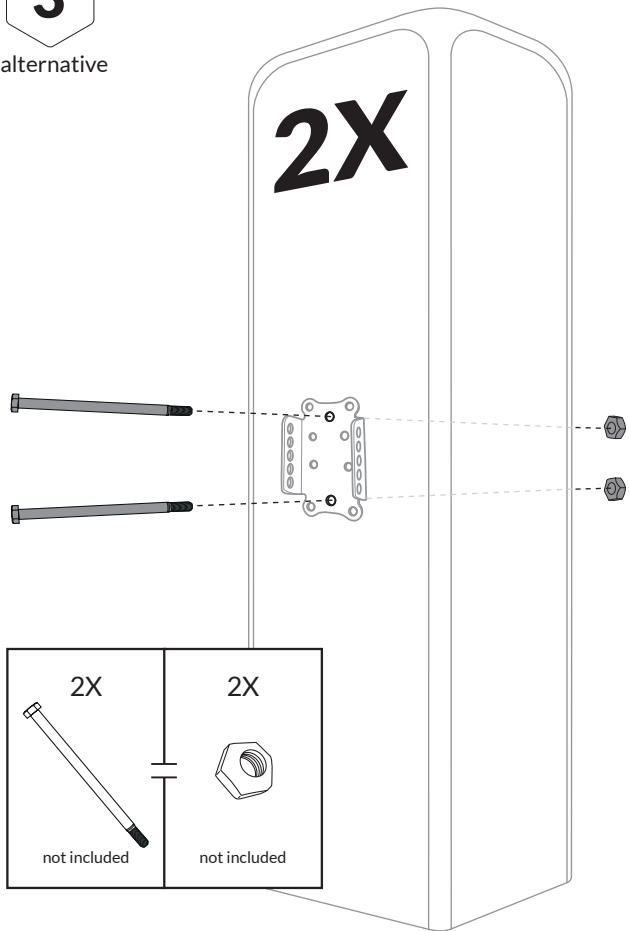

STEP
4

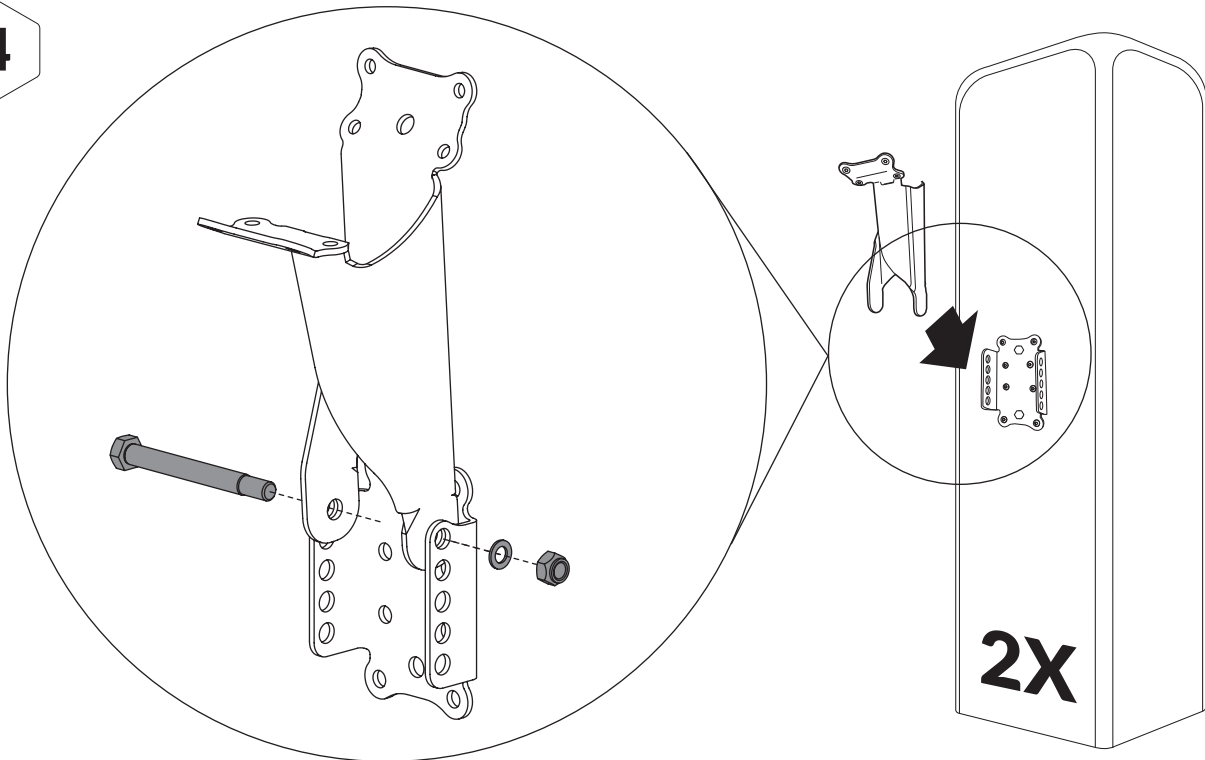

STEP
5

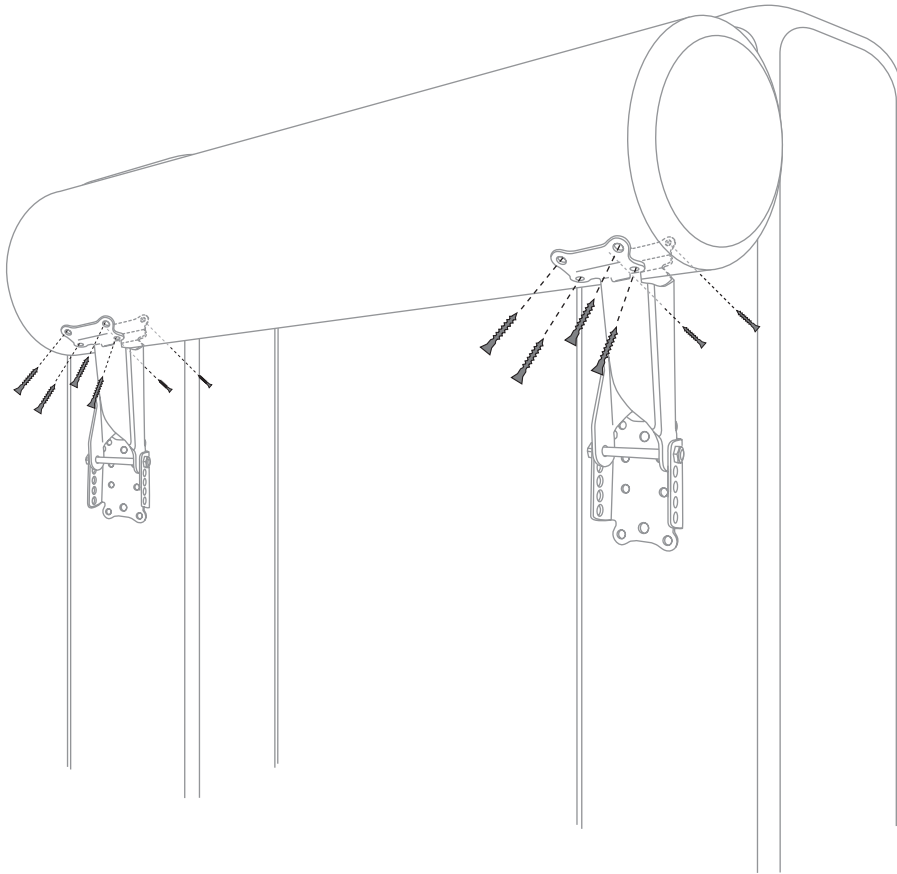

12X

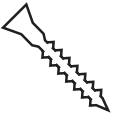



not included

STEP
5*

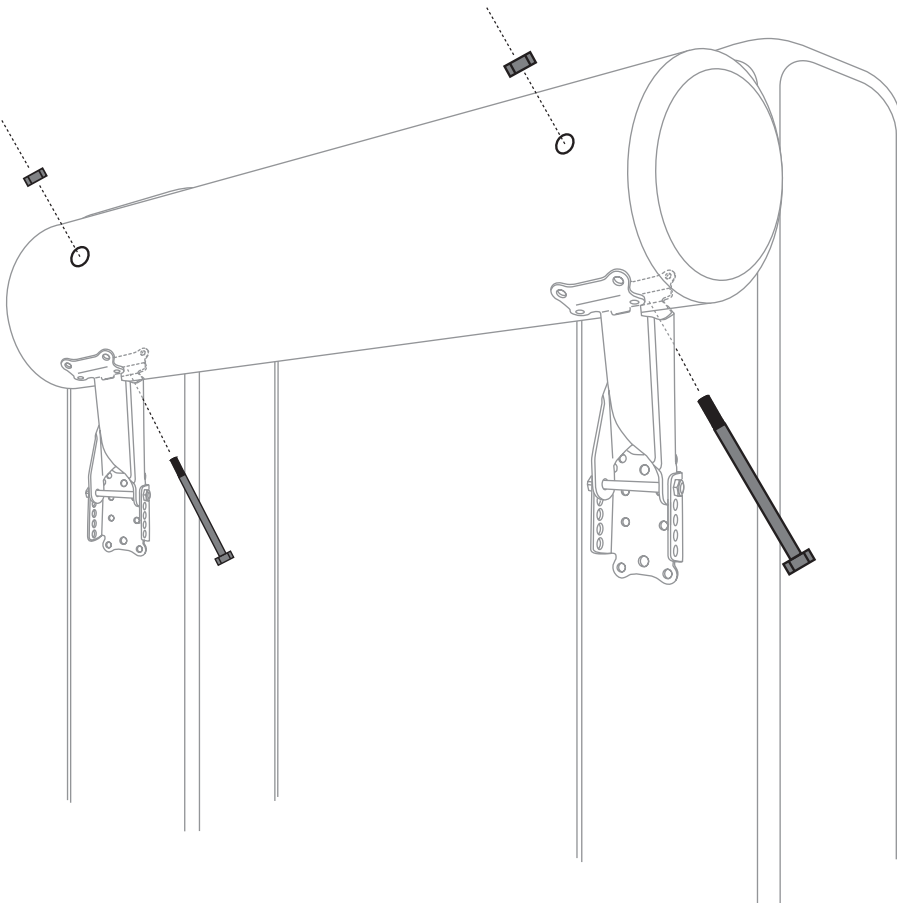
*alternative



2X	2X
	
not included	not included

STEP
6

CORRECT alignment of the clip

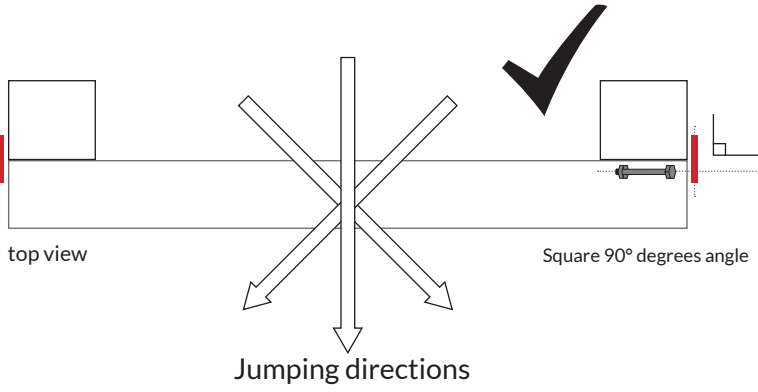

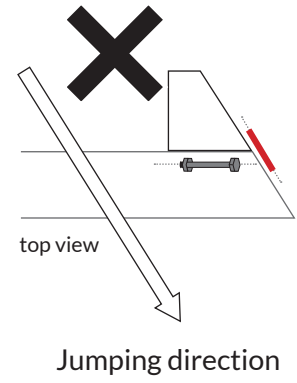

WRONG alignment of the clip



STEP
7*

*alternative

M-TS10X90 2X 	8X not included 
--	---

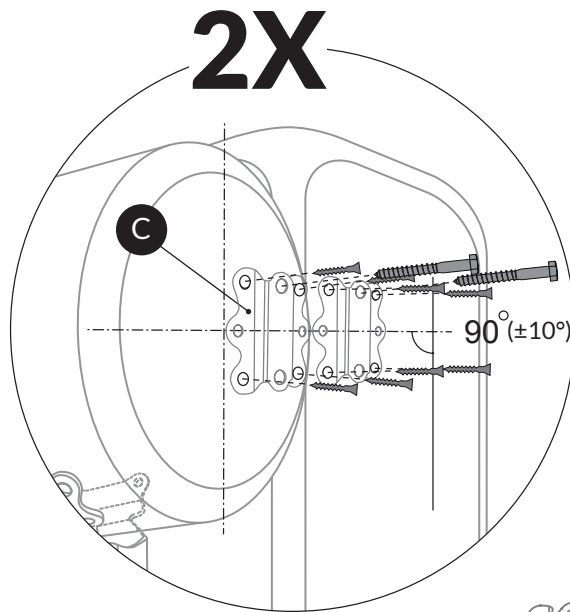

This position is to be used for
**INTENDED NORMAL
APPROACHING SPEED**

The **C** pieces must be:

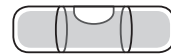

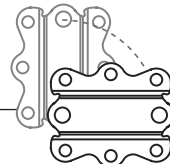

**PARALLEL AND
HORIZONTALLY LEVELLED**



Alt. positioning

STEP
7*

*alternative

M-TS10X90 2X 	8X not included 
--	---

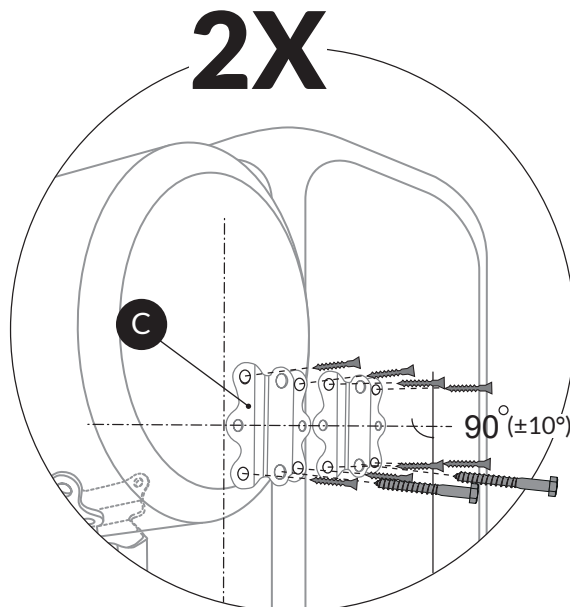

This position is to be used for
**INTENDED LOW
APPROACHING SPEED**
and/or
**JUMP WHICH COULD BE
JUMPED AT AN ANGLE**

The **C** pieces must be:



**PARALLEL AND
HORIZONTALLY LEVELLED**

STEP
8

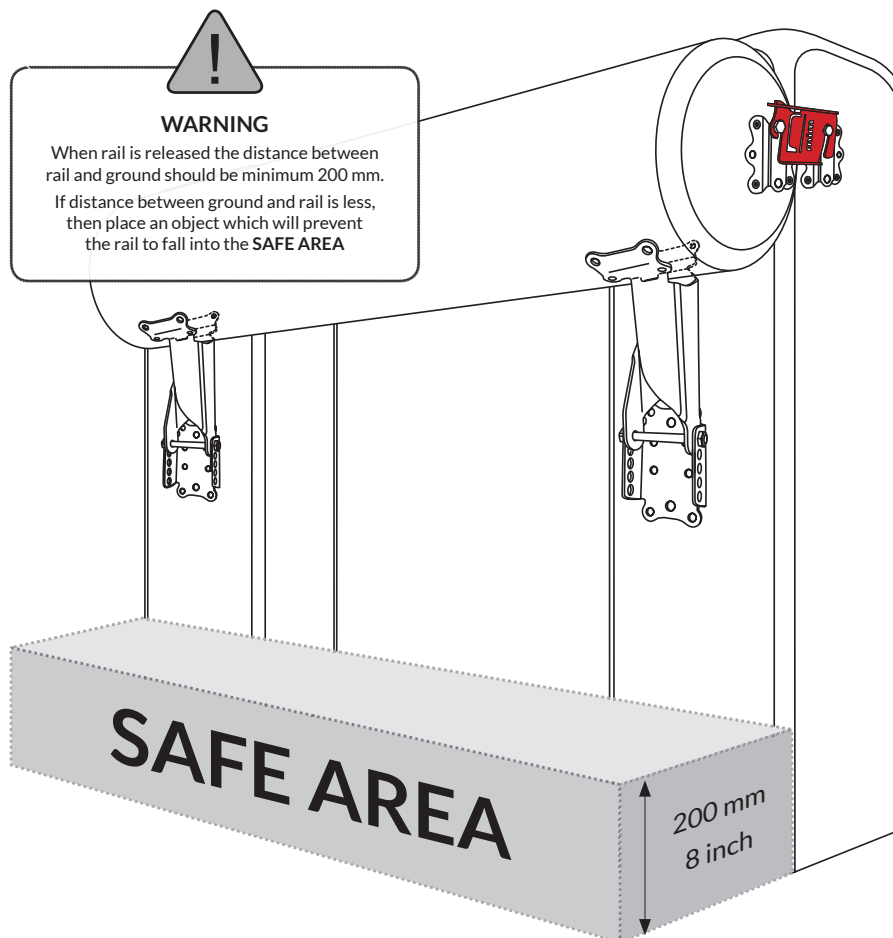
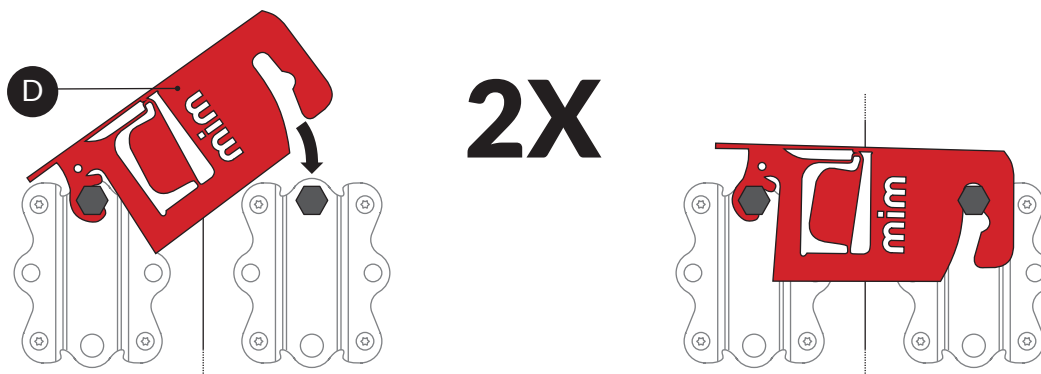

The advantages of the Post & Rail Kit

1. It has been produced with safety being the first and foremost important factor.
2. Reduces the possibility of rotational falls.
3. FEI approved number FEI01SWE.
4. Controlled movement of fence during release.
5. Reconstruction time is less than 30 seconds.
6. The parts are made of powder coated steel and can be left outside, no maintenance is required.
7. The very highest quality of product from Sweden.

The Mim clip (F18C) breaks on impact, which clearly indicates when replacement is needed. The rail is connected to the post with a hinge that makes the fence easy to reconstruct. This saves time, guarantees fair and correct judging for riders and contributes to the overall safety of the sport.